

FLOOR MACHINES

Parts for M-SERIES MACHINES

Models M171, M171HD, M171SD

58	X8912	switch box cover
59	X8914	thumb actuation release
60	X8917	handle trigger

61	X8916	trigger tension spring, 2
62	X8915	handle trigger thumb actuation spring
63	X8918	handle roller pin, 2
64	X8941	handle grip, 2
65	X8207	#10-24 screw, 3
	7CY001	lock washer, 3
66	X8923	insulation sheet
67	F5P	switch
69	7BG004	7/16" diameter grommet
70	X8222	1/4-20 x 3/16" set screw

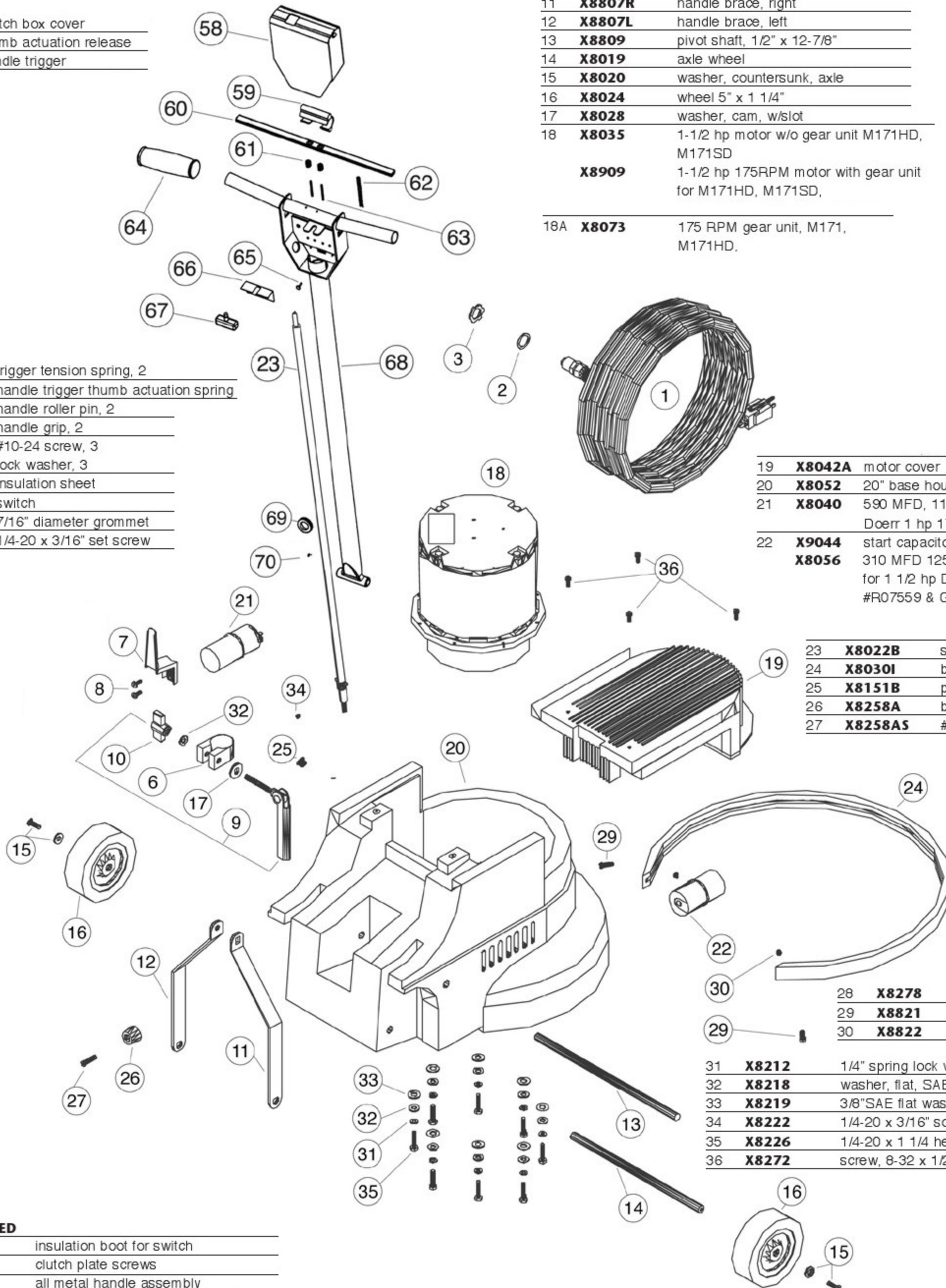

ref #	order	description
1	M1369GS	sub, 14/3 STWA, 50' gray,
2	SR36	strain relief washer
3	X8008N	nut, lock, 1/2" steel conduit
6	X8012	clamp, collar, handle
7	X8013	cord hook, plated
8	X8207	screw, 10-24 x 1/2", phph, type "I"
9	X8012A	handle clamp assembly
10	X8016	knob, plastic, handle release
11	X8807R	handle brace, right
12	X8807L	handle brace, left
13	X8809	pivot shaft, 1/2" x 12-7/8"
14	X8019	axle wheel
15	X8020	washer, countersunk, axle
16	X8024	wheel 5" x 1 1/4"
17	X8028	washer, cam, w/slot
18	X8035	1-1/2 hp motor w/o gear unit M171HD, M171SD
	X8909	1-1/2 hp 175RPM motor with gear unit for M171HD, M171SD,
18A	X8073	175 RPM gear unit, M171, M171HD.

19	X8042A	motor cover
20	X8052	20" base housing
21	X8040	590 MFD, 110V start capacitor for Doerr 1 hp 175 RPM motor
22	X9044	start capacitor, 3 post, 1.5 hp 450 mh
	X8056	310 MFD 125V start capacitor for 1 1/2 hp Doerr Model #R07559 & G51400

23	X8022B	sub., cord, in-line 14/3 SJTWA 49"
24	X8030I	bumper 38.25" blu/blk
25	X8151B	plug, plastic, 7/16" hole, for base housing
26	X8258A	bumper, blk, 1.13" od x .75" h
27	X8258AS	#8 x 1" phph type A

28	X8278	3-32 x 1/2" phph, black oxide
29	X8821	screw, 8-32 x 3/4", thph, blk plated
30	X8822	spacer, #8 x .25, plastic black
31	X8212	1/4" spring lock washer
32	X8218	washer, flat, SAE 5/16"
33	X8219	3/8" SAE flat washer
34	X8222	1/4-20 x 3/16" socket set
35	X8226	1/4-20 x 1 1/4 hex head cap
36	X8272	screw, 8-32 x 1/2", truss/ph,

NOT ILLUSTRATED

PX28	insulation boot for switch
X8575	clutch plate screws
X8911	all metal handle assembly
M8600-3	handle retro kit, M series all metal
X8265	bolt
X8530	2 speed controller

*Ref numbers 58-68 may be order as a complete assembly - **M8600-3**

FLOOR MACHINES

Parts for M-SERIES MACHINES

"M" series Pre 2003 handle parts

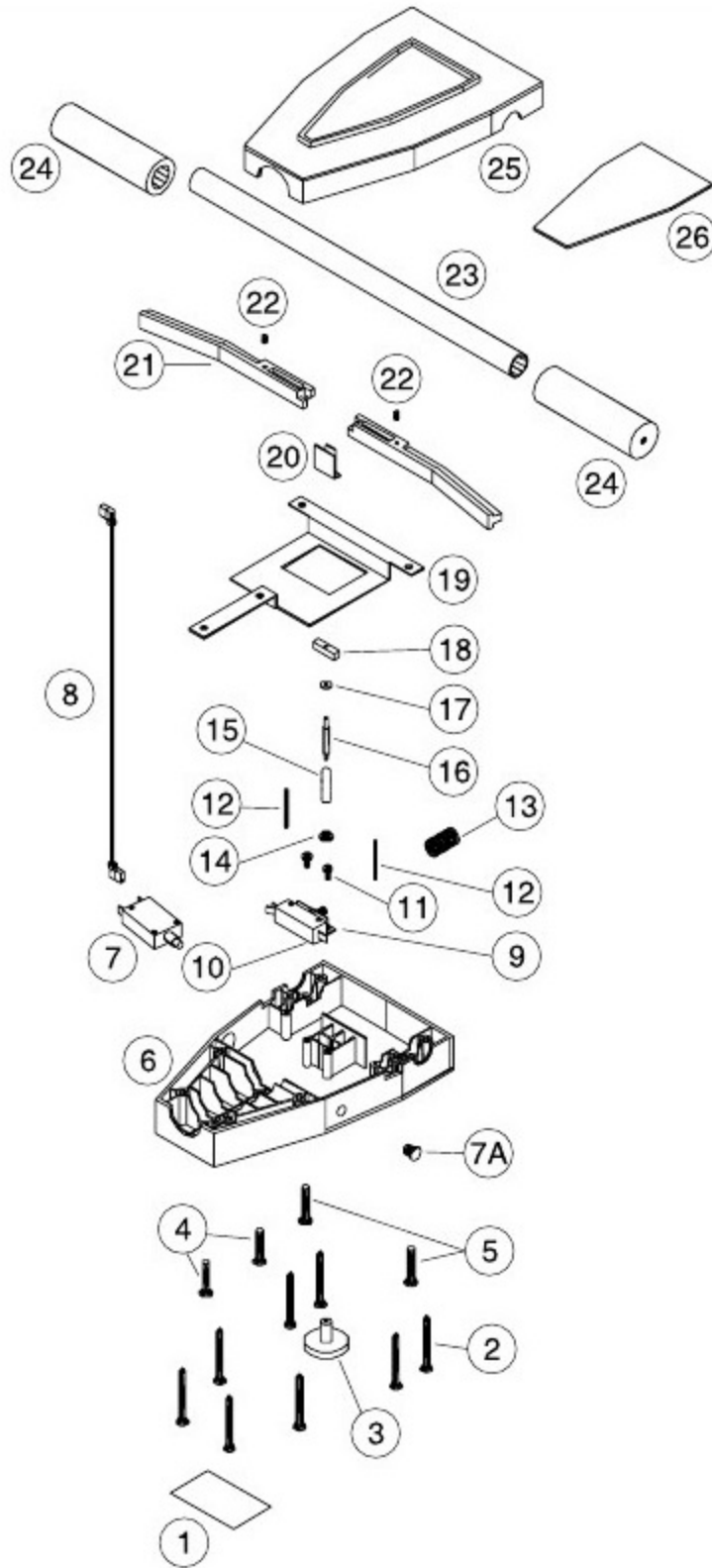

ref	order	description
	M8600	complete handle assembly
1	X8418A	warning label
2	X8820	12 x 2 phil flat ts-a
3	X8805	lock out knob
4	X8819	1/4 x 1-1/4 phil flat mach scr
5	X8818	1/4 x 1-1/2 phil flat tc-f
6	X8002A	bottom handle housing
7	X8023A	circuit breaker, 15a, w/nuts
7A	X8151C	3/8" hole plug
8	X8009	lead, 14g, blk, 4", w/2 f26
9	X8006	switch bracket
10	F5P	momentary switch 1901-012104
11	X8284	8-32 x 3/8" phph, type F
12	X8026	trigger pin
13	X8010	switch spring
14	X8823	lock-out bushing
15	X8814	spring, od .312, wire dia .025
16	X8804	lock-out rod
17	X8817	#6 SAE flat washer, black
18	X8803	lock out stop
19	X8806	plate, handle support
20	X8061	clip switch lever
21	X8003	handle switches trigger
22	X8110A	compression spring
23	X8005	cross bar handle
24	X8007	handle grip
25	X8001A	top handle housing
26	X8815	handle, back, M-series, w/label

DELTAQUIP

www.deltaquip.ca (604) 298-8996

SUPPLIES LTD.