

Replacing the Motor

1. Perform the Pressure Relief Procedure and unplug the sprayer.
2. Loosen and remove the two motor cover screws. Remove the motor cover.
3. Loosen and remove the three belly pan screws. Remove the belly pan.
4. On the back of the motor, disconnect the wire coming from the potentiometer and the wire coming from the transducer. Also, disconnect the two wires coming from the control panel board (refer to the electrical schematic in the Parts List section of this manual).
5. Remove the four control panel mounting screws. Pull back the control panel for access to the control panel board.
6. At the the control panel board, disconnect the two wires coming from the motor (refer to the electrical schematic in the Parts List section of this manual).
7. Loosen and remove the four motor mounting screws.
8. Pull the motor out of the pump housing.

NOTE: If the motor will not dislodge from the pump housing:

- Remove the front cover plate.
- Using a rubber mallet, carefully tap on the front of the motor crankshaft that extends through the slider assembly.

9. With the motor removed, inspect the gears in the pump housing for damage or excessive wear. Replace the gears, if necessary.
10. Install the new motor into the pump housing.
11. Secure the motor with the four motor mounting screws.
12. Reconnect the wires (refer to the electrical schematic in the Parts List section of this manual).
13. Position the control panel on the pump housing and secure in position using the four control panel mounting screws.
14. Replace the belly pan. Secure with the three belly pan screws.
15. Slide the motor cover over the motor. Secure the motor cover with the two motor cover screws.

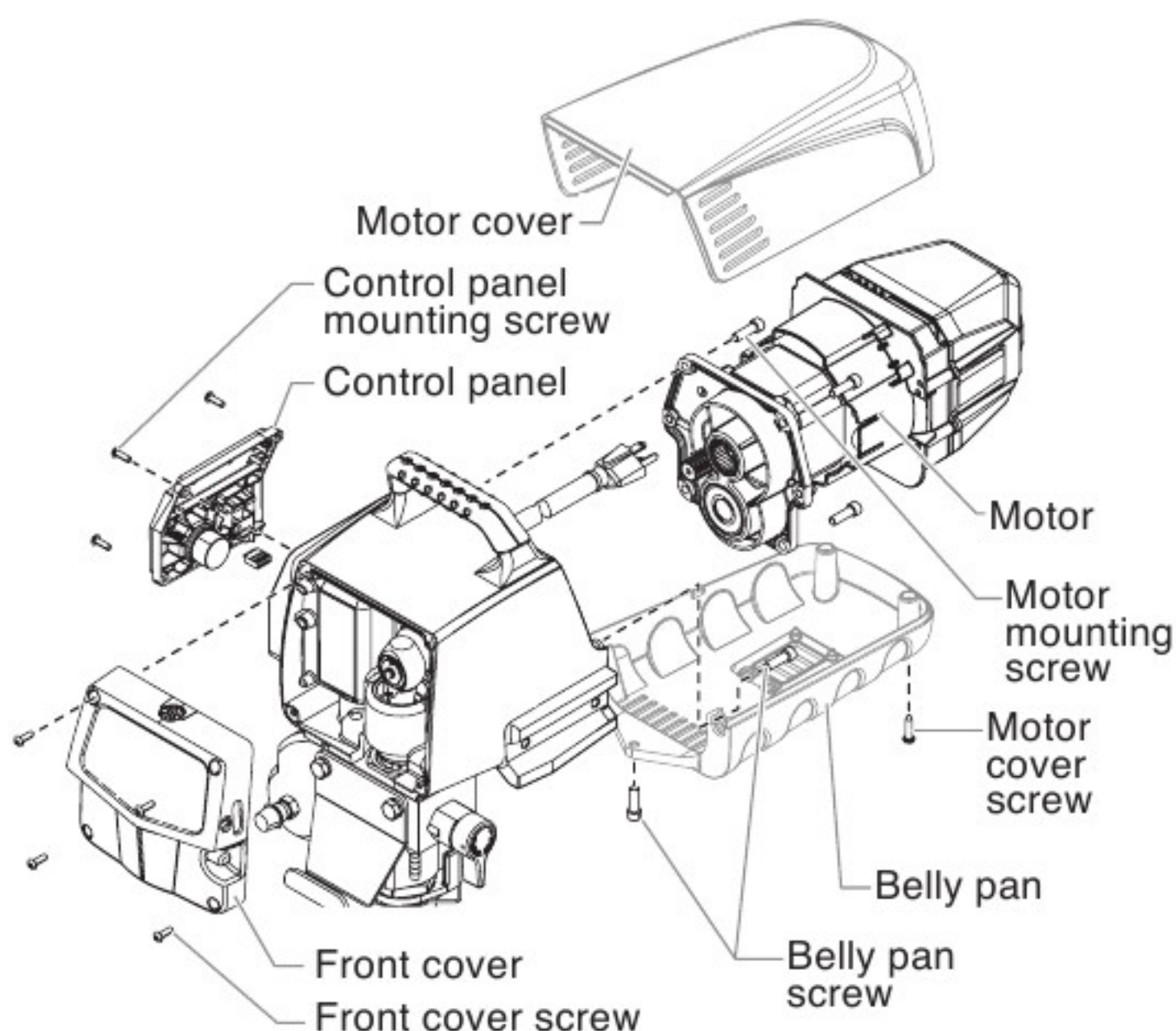

Replacing the Gears

1. Perform the Pressure Relief Procedure and unplug the sprayer.
2. Loosen and remove the two motor cover screws. Remove the motor cover.
3. Loosen and remove the three belly pan screws. Remove the belly pan.
4. On the back of the motor, disconnect the wire coming from the potentiometer and the wire coming from the transducer. Also, disconnect the two wires coming from the control panel board (refer to the electrical schematic in the Parts List section of this manual).
5. Remove the four control panel mounting screws. Pull back the control panel for access to the control panel board.
6. At the the control panel board, disconnect the two wires coming from the motor (refer to the electrical schematic in the Parts List section of this manual).
7. Loosen and remove the four motor mounting screws.
8. Pull the motor out of the pump housing.

NOTE: If the motor will not dislodge from the pump housing:

- Remove the front cover plate.
- Using a rubber mallet, carefully tap on the front of the motor crankshaft that extends through the slider assembly.

9. Inspect the armature gear on the end of the motor for damage or excessive wear. If this gear is completely worn out, replace the entire motor.
10. Remove and inspect the 2nd stage gear for damage or excessive wear. Replace if necessary.
11. Remove and inspect the gear and crank assembly for damage or excessive wear. Replace if necessary.
12. Reassemble the pump by reversing the above steps. During reassembly, make sure the thrust washer is in place.

NOTE: Refill the gear box in the pump housing with five ounces of Lubriplate (P/N 314-171).

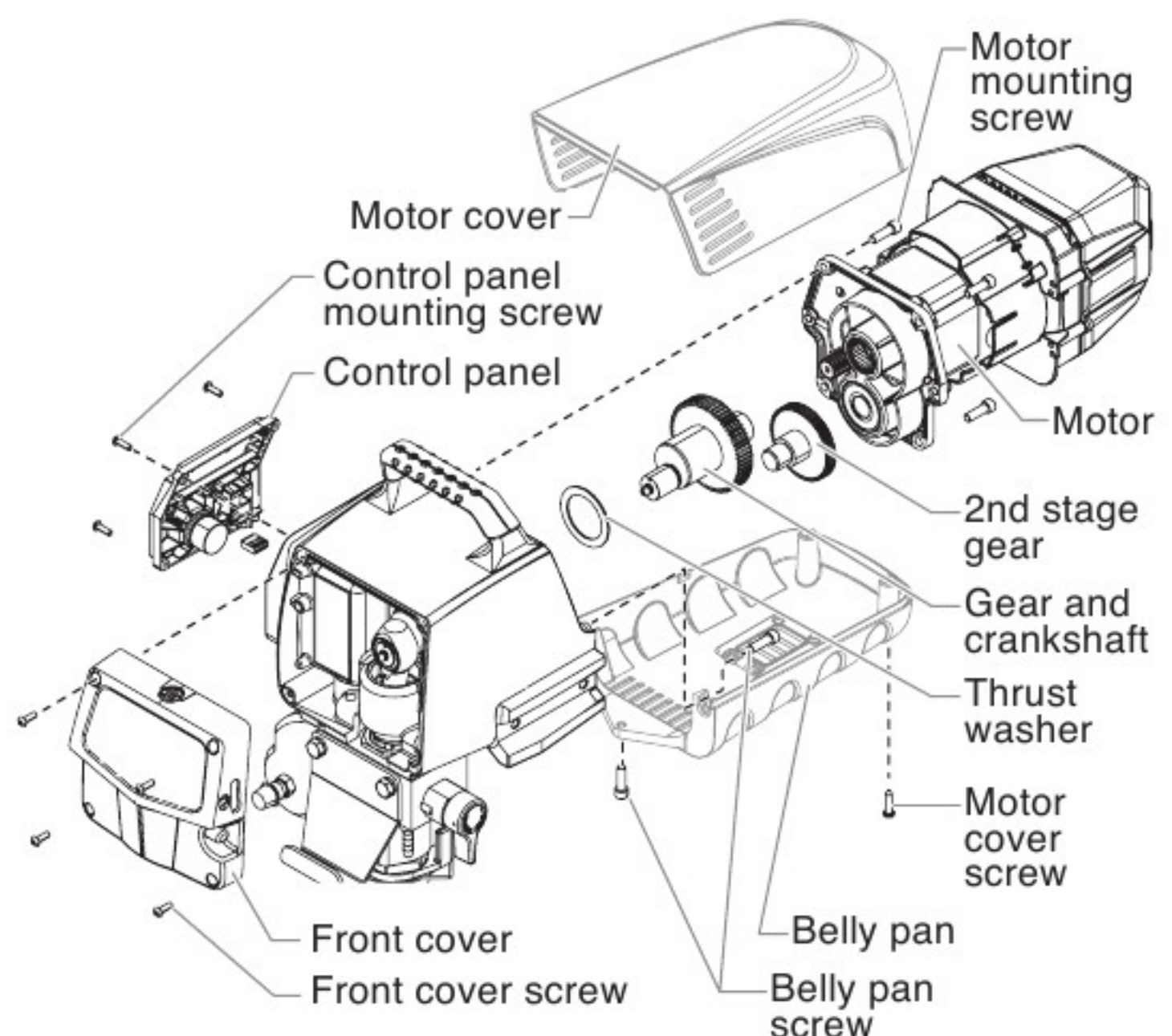

Replacing the Transducer

1. Loosen and remove the four front cover screws. Remove the front cover.
2. Stop the sprayer at the bottom of its stroke so that the piston is in its lowest position.
3. Perform the Pressure Relief Procedure and unplug the sprayer.



Before proceeding, follow the Pressure Relief Procedure outlined previously in this manual. Additionally, follow all other warnings to reduce the risk of an injection injury, injury from moving parts or electric shock. Always unplug the sprayer before servicing!

4. Tilt the pump back for easy access to the fluid section.
5. Using a 3/8" hex wrench, loosen and remove the two pump block mounting screws.
6. Pull the pump block down approximately 1/2" from the pump housing to clear the transducer.
7. Slide the pump block and piston rod forward until the piston rod is out of the T-slot on the slider assembly.
8. Carefully pull the transducer wire out of the pump housing until the connection to the transducer jumper is exposed. Unplug the wire from the transducer jumper (refer to the electrical schematic in the Parts List section of this manual).
9. Using a wrench, remove the transducer assembly from the pump block.
10. Thread the new transducer assembly into the pump block. Tighten securely with a wrench.
11. Plug the new transducer wire into the transducer jumper (refer to the electrical schematic in the Parts List section of this manual).
12. Reassemble the pump by reversing steps 1–7.

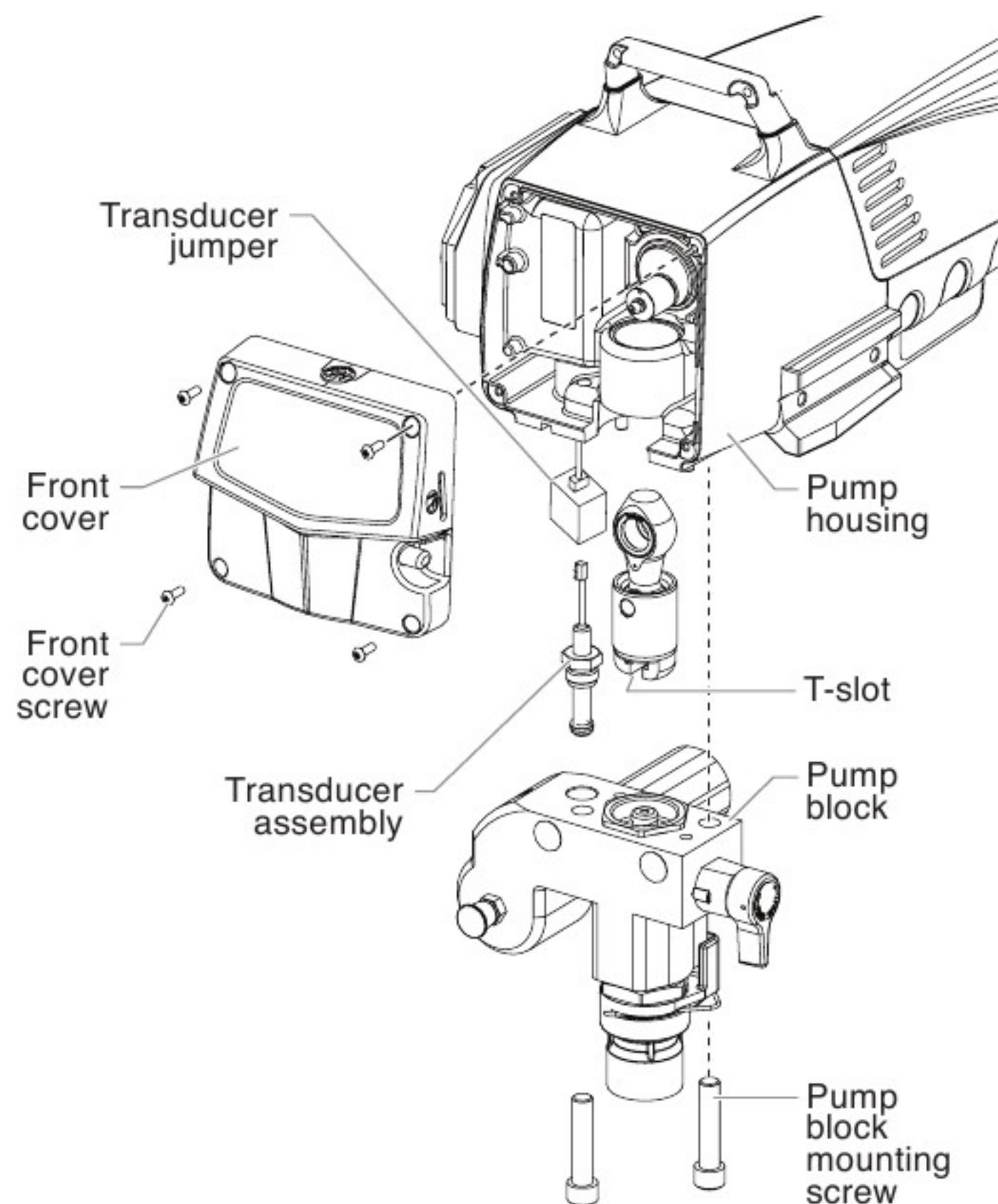

Replacing the PRIME/SPRAY Valve

Perform the following procedure using PRIME/SPRAY valve replacement kit P/N 700-258.

1. Push the groove pin out of the valve handle.
2. Remove the valve handle and the cam base.
3. Using a wrench, loosen and remove the valve housing assembly.
4. Make sure the gasket is in place and thread the new valve housing assembly into the pump block. Tighten securely with wrench.
5. Place the cam base over the valve housing assembly. Lubricate the cam base with grease and line up the cam with the pump block.
6. Line up the hole on the valve stem with the hole in the valve handle.
7. Insert the groove pin into the valve handle and through the valve stem to secure the valve handle in position.

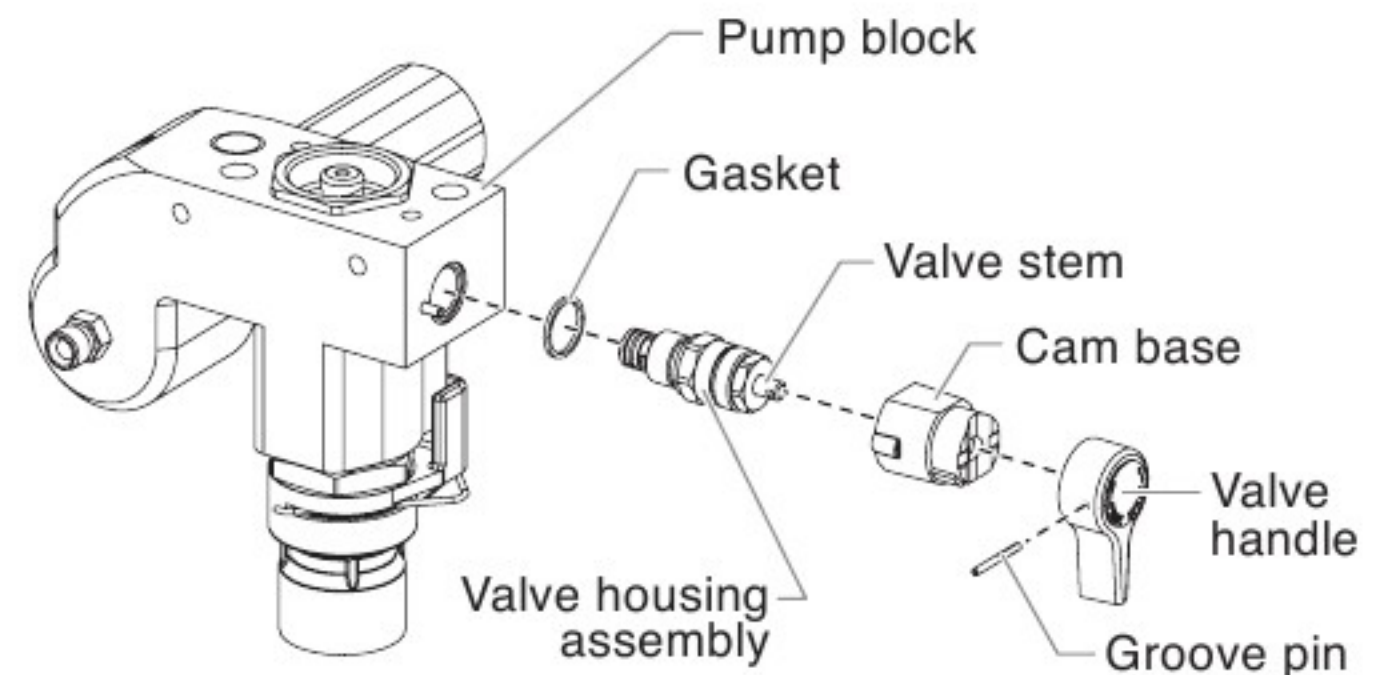

Servicing the Fluid Section

Use the following procedures to service the valves and repack the fluid section. Perform the following steps before performing any maintenance on the fluid section.

1. Loosen and remove the four front cover screws. Remove the front cover.
2. Stop the sprayer at the bottom of its stroke so that the piston is in its lowest position.
3. Perform the Pressure Relief Procedure and unplug the sprayer.



Before proceeding, follow the Pressure Relief Procedure outlined previously in this manual. Additionally, follow all other warnings to reduce the risk of an injection injury, injury from moving parts or electric shock. Always unplug the sprayer before servicing!

4. Unscrew the return hose assembly from the pump block. Remove the retaining clip from the bottom of the foot valve housing. Remove the siphon assembly.
5. Tilt the sprayer back for easy access to the fluid section.

Servicing the Valves

The design of the fluid section allows access to the foot valve and seat as well as the outlet valve and seat without completely disassembling the fluid section. It is possible that the valves may not seat properly because of debris stuck in the foot valve seat or outlet valve seat. Use the following instructions to clean the valves and reverse or replace the seats.

1. Remove the pusher stem clip and slide the pusher stem housing from the foot valve housing.
2. Using a wrench, loosen and remove the foot valve housing from the pump block.
3. Clean out any debris in the foot valve housing and examine the valve housing and seat. If the seat is damaged, reverse or replace the seat.
4. Using a 5/16" hex wrench, loosen and remove the outlet valve retainer from the piston rod.

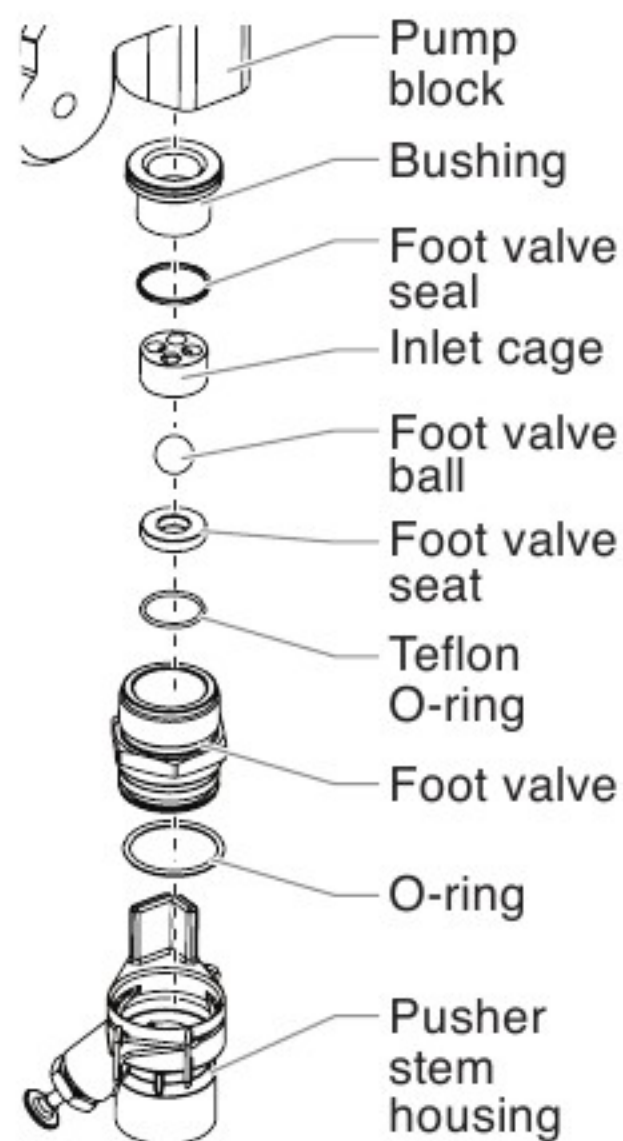

NOTE: Always service the outlet valve with the piston rod attached to the pump. This will prevent the piston rod from rotating during disassembly of the outlet valve.

5. Clean out any debris and examine the outlet valve housing and seat. If the seat is damaged, reverse or replace the seat.
6. Remove, clean, and inspect the outlet cage, crush washer, and outlet valve ball. Replace if they are worn or damaged.

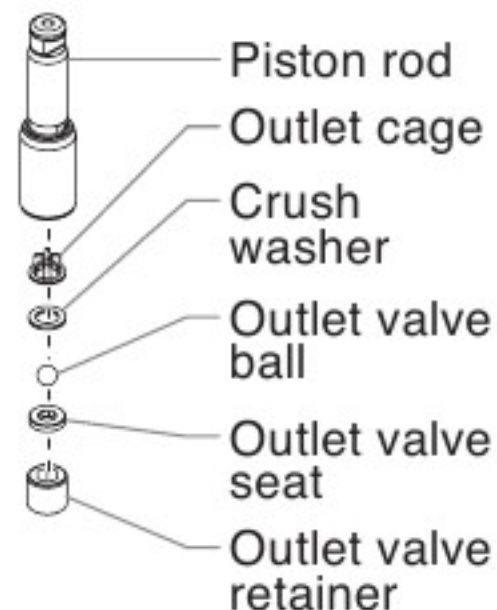

NOTE: The outlet cage always must be used with the crush washer. They are included together in the repacking kit as assembly P/N 704-642.

7. Reassemble the valves by reversing the steps above.

NOTE: During reassembly of the outlet valve, apply one drop of Loctite (included in the repacking kit) to the threads of the outlet valve retainer before threading it into the piston rod. Then, torque the retainer to 144 in./lbs. (12 ft./lbs.).

Repacking the Fluid Section

1. Remove the foot valve assembly using the steps in the "Servicing the Valves" procedure above.

NOTE: The outlet valve does not need to be disassembled from the piston rod for this procedure.

2. Using 3/8" a hex wrench, loosen and remove the two pump block mounting screws.
3. Pull the pump block down approximately 1/2" from the pump housing.
4. Slide the pump block and piston rod forward until the piston rod is out of the T-slot on the slider assembly.
5. Slide the piston rod out through the bottom of the pump block.
6. Loosen and remove the retainer nut and piston guide from the pump block.
7. Remove the upper and lower packings from the pump block.
8. Clean the pump block and install the new upper and lower packings. Refer to the illustration below for proper packing orientation.

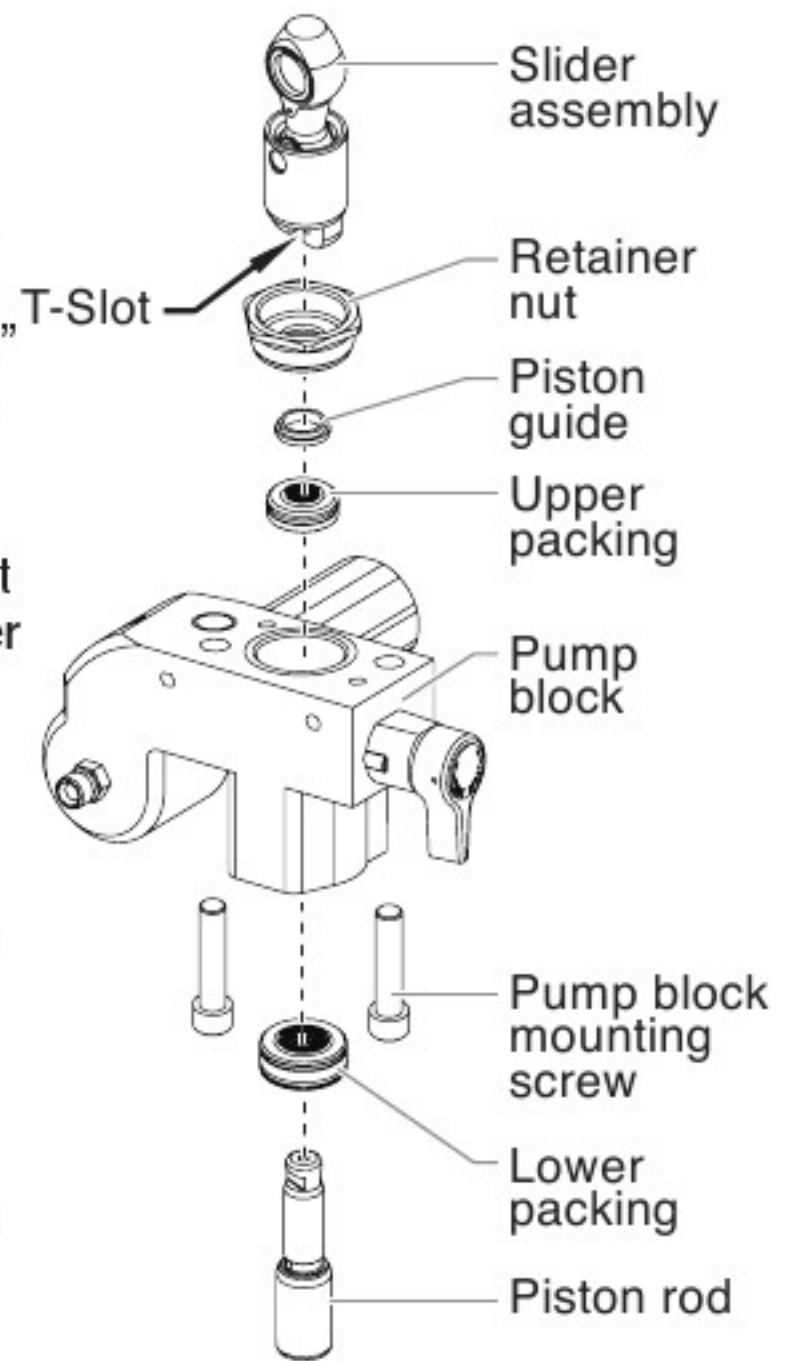

Install upper packing with raised lip and O-ring facing down.



Install lower packing with the beveled edge facing up.

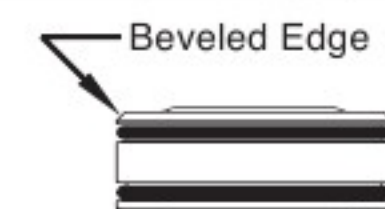

9. Inspect the piston rod for wear and replace if necessary.
10. Reassemble the outlet valve assembly into the piston rod. Tighten the outlet valve retainer with a wrench until secure.

NOTE: Use the T-slot on the slider assembly to hold the piston rod in position while securing the outlet valve retainer.

IMPORTANT: Never use a wrench on the piston itself. This could cause damage to the piston and cause leakage.

11. Insert the piston guide into the retainer nut. Thread the retainer nut into the pump block until it is hand tight.
12. Slide the piston guide tool (included in the repacking kit) over the top of the piston rod and insert the piston rod through the bottom of the pump block. Using a rubber mallet, tap the bottom of the piston rod lightly until the piston rod is in position in the pump block.

NOTE: Coat the piston guide tool and the piston rod with grease before inserting them into the pump block.

13. Using a wrench, tighten the retainer nut securely.
14. Slide the top of the piston rod into the T-slot on the slider assembly.
15. Position the pump block underneath the pump housing and push up until it rests against the pump housing.
16. Thread the pump block mounting screws through the pump block and into the pump housing. Tighten securely.
17. Reassemble the foot valve assembly into the pump block.
18. For High Rider cart units, thread the siphon tube into the foot valve and tighten securely. Make sure to wrap the threads on the siphon tube with Teflon tape before assembly. Replace the return hose into the hose clip on the siphon tube.
19. For Skid and Low Rider units, insert the elbow on the siphon assembly into the bottom of the foot valve housing. Push the retaining clip up into the groove inside the foot valve housing to secure the siphon assembly in position. Thread the return hose into the pump block and tighten securely.
20. Place the front cover on the pump housing and secure in position using the four front cover screws.
21. Turn on the sprayer by following the procedure in the "Operation" section of this manual and check for leaks.

NOTE: Repacking kit P/N 704-586 is available. For best results use all parts supplied in this kit.

Replacing the Filters

Pump Filter

1. Loosen and remove the filter housing by hand.
2. Slip the filter off of the filter support spring.
3. Inspect the filter. Based on inspection, clean or replace the filter.
4. Inspect the seal. Based on inspection, clean or replace the seal.
5. Slide the new or cleaned filter over the filter support spring with the adapter in place. Push the filter into the center of the pump block.
6. Slide the filter housing over the filter and thread it into the pump block until secure.

NOTE: The filter housing should be hand-tightened, but make sure the filter housing is seated fully into the pump block.

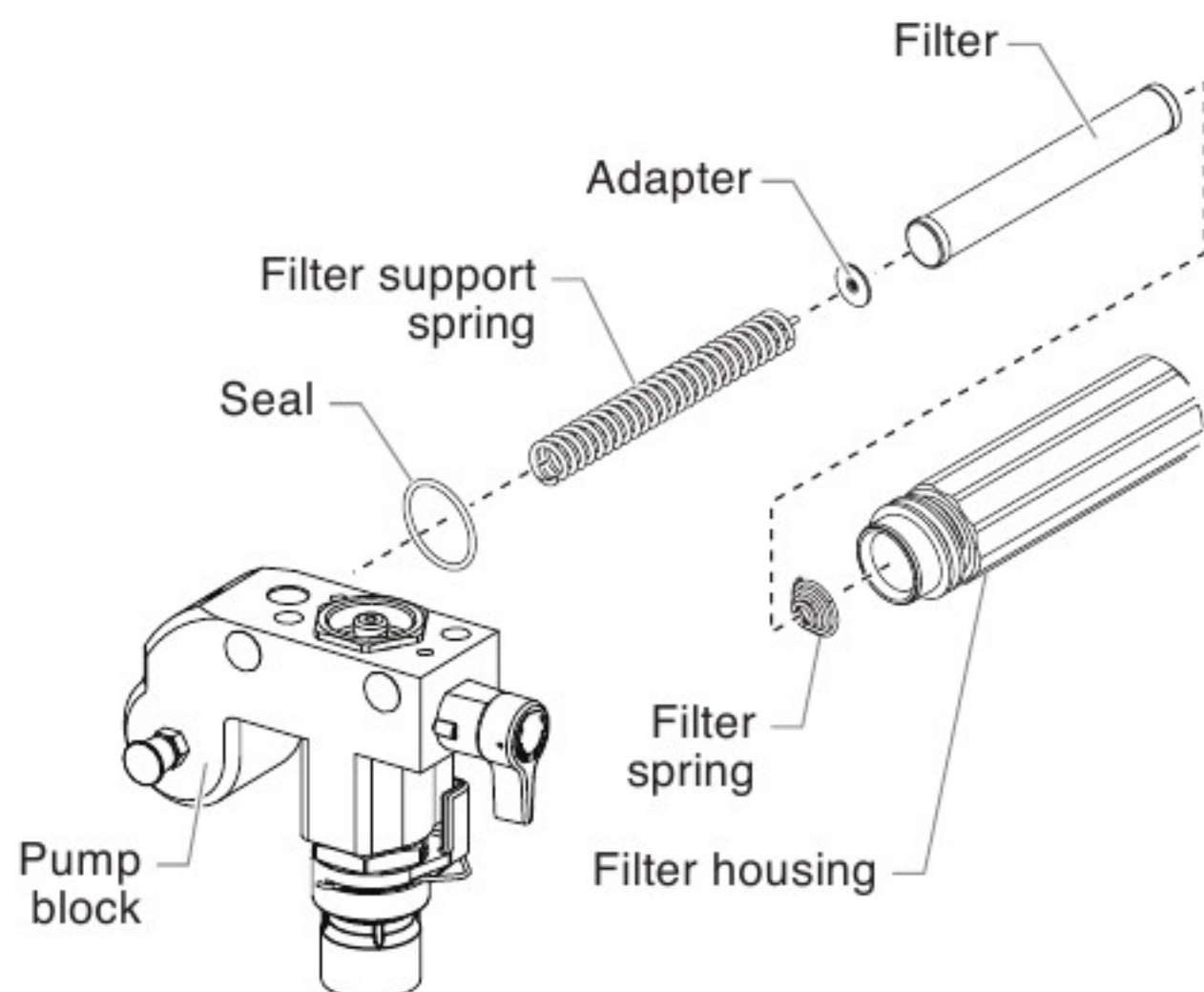

Gun Filter

1. Move the gun trigger lock to the unlocked position.
2. Loosen and remove the handle from the gun body.
3. Turning clockwise, unscrew the filter from the gun body.

NOTE: Left-handed threads require turning the filter clockwise to remove.

4. Turning counterclockwise, screw the new or cleaned filter into the gun body.
5. Make sure the handle seal is in position and thread the handle into the gun body until secure.
6. Move the gun trigger lock to the locked position.

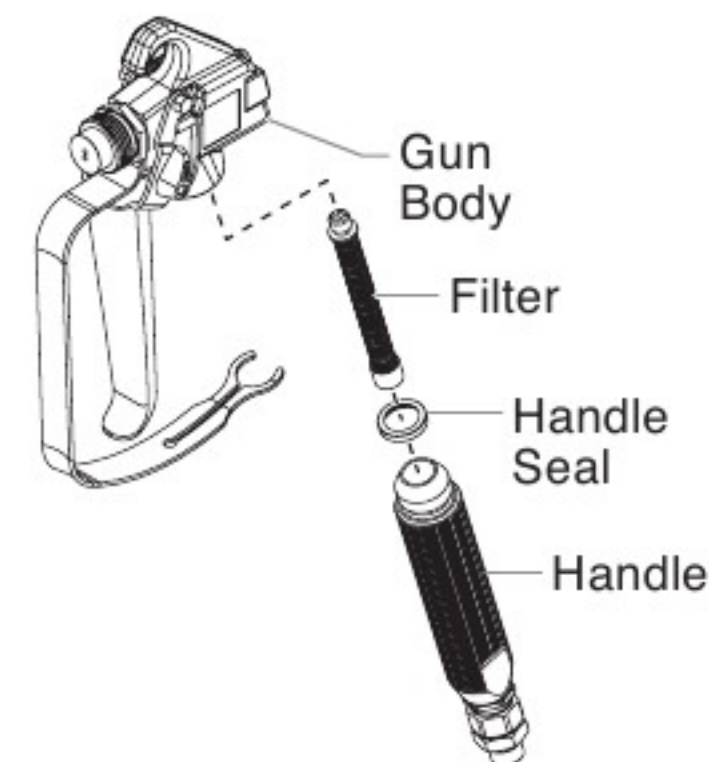

NOTE: For more detail, part number information, and complete assembly drawings, please see the LX-80II Professional Airless Gun Owner's Manual (P/N 313-2293).